

**Ultronics™ ZTS16**  
Twin Spool Valve

130 LPM  
350 Bar

Electronic Load  
Sense

CAN Bus



**EATON**

*Powering Business Worldwide*

# Table of Contents

General Information .....	3
Specifications .....	4
Model Code .....	6
Principles of Operation .....	8
Performance Data .....	9
Inlet Options .....	10
Flow Share Methods .....	11
Electrical .....	12
System Layout .....	13
Work Port Valves .....	14
Manual Override .....	15
Interbank Connection Cables .....	16
Installation Drawings .....	17

# General Information

## Product Overview

The new Ultronic ZTS16 (referred to herein as Ultronic) electronic load sense control valve delivers high performance and reliable valve control during high demand, multi-functioning operational environments. This is possible via:

- Patented twin spool design
- Integrated pressure and position sensors
- On-board electronics & data processing
- Open architecture
- 130 LPM (35 gpm) flow rating
- 350 bar max pressure rating
- CANbus interface (J1939 or CANopen)

With its open architecture and CAN interface, Ultronic has the ability to be a complete Eaton control system\* or simply a stand-alone valve solution in a nearly-infinite array of applications for customers and end-users.

### \*Systems offerings may include

- Eaton EFX controllers
- Eaton ControlF(x)<sup>®</sup> software
- Ultronic Joysticks

## Features and Benefits

### Configurable Performance

Configurable valve parameters allow for rapid and broad changes in valve performance, which reduces system development time, improves productivity without hardware changes.

### Precise Control

A patented independent twin spool design allows precise control of meter-in and meter-out flow under varying load conditions. This reduces inefficiencies and performance compromises with traditional single spool designs.

### Real-Time Diagnostics and Monitoring

Integrated sensors and configuration software enables real-time diagnostics and performance monitoring. Thus, system developers can quickly and efficiently trouble-shoot and commission new systems.

### Unique Applications Functionality

Ultronic's open architecture allows users to develop their own application level programs using Eaton's Control F(x)<sup>®</sup> software and EFX controllers, or by using their own controller and associated software. This facilitates advanced system functionality and flexibility.

# Specifications

## Pressure

Inlet (max)*	350 bar (5100 psi)
Work port (max)*	350 bar (5100 psi)
Tank**	Min. 2 bar (30 psi), Max. 30 bar (435 psi)

## Flow

Inlet (max)	200 lpm (53 gpm)
Work port (max)	130 lpm (34 gpm)

## Temperature

Ambient (operating)	-40°C to 105°C
Oil (operating)	-20°C to 85°C
Storage	-40°C to 120°C

## Filtration

ISO 4406	18/16/13
----------	----------

## Electrical

Input Voltage	9 – 32 VDC
CAN Interface	J1939 2.0B
	CAN Open

## Electromagnetic

Conducted Emissions	CISPR 25: 2002
Radiated Emissions	CISPR 25: 2002
Transient Emissions	ISO 7637-2: 2004
Radiated Immunity	ISO 11452, CISPR 25: 2002, 2004/104/EC
Electrostatic Discharge	ISO 10605 and SAE J1113-13
Power Frequency Magnet Field Immunity	EN 61000-4-8
Reverse Supply Protection	-36V
Transients Immunity	ISO 7637-2:2004

## Environmental

Ingress Protection	IP67
--------------------	------

**\*Note:** Valve tested at 350 bar for 1 million cycles per NFPA T 2.6.1. Rated pressure per T 2.6.1. is 300 bar (4350 psi).

**\*\*Note:** With manual override, tank is limited to 10 bar (145 psi) maximum.

# Specifications

## Viscosity

Recommended Viscosity	85 to 10 cSt	85 to 10 mm <sup>2</sup> /s
Absolute Maximum Viscosity	2250 cSt	2250 mm <sup>2</sup> /s
Absolute Minimum Viscosity	7 cSt	7 mm <sup>2</sup> /s

## Leakage

Max Leakage*	23 cc @ 100 Bar @ 23 cst
--------------	--------------------------

\* Data taken from work port to tank

# Model Code

**Note:** Model code represents single valve bank. Multiple valve bank systems will have multiple model codes.

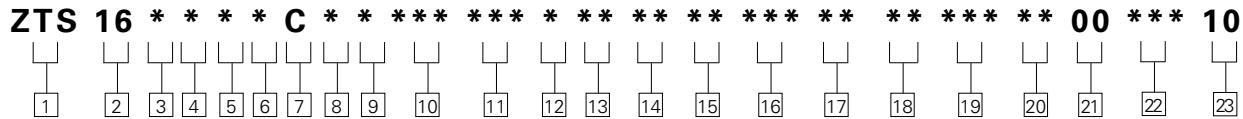

**1 Valve Series**  
**ZTS** – Ultrionics ZTS16

---

**2 Spool**  
**16** – Size

---

**3 Communication Interface**  
**J** – J1939 CAN 2.0B  
**O** – CAN-Open

---

**4 Interface Module**  
**M** – VSM - Valve System Module. One required per system located on first valve bank in system  
**E** – VSE - Valve System Extender. Required when valve bank is greater than 4 meters from previous valve bank in system  
**0** – None - When valve is less than 4 meters from a VSM or VSE valve bank and daisy chain is desired  
**Note:** if “0” is chosen, an interconnection cable must be ordered separately. See note below for part numbers.  
**Note:** Maximum of 2 VSE allowed per system.

**5 CAN Bus Terminator**  
**T** – One Section  
**0** – No CAN bus terminator - true when valve bank is the start of, or within, a daisy chain

---

**6 Number of Sections in Valve Bank**  
**1** – One Section  
**2** – Two Sections  
**3** – Three Sections  
**4** – Four Sections  
**5** – Five Sections  
**6** – Six Sections

---

**7 Bank Type**  
**C** – Standard valve bank

**8 Main Ports**  
**S** – Supply Ports: 1-1/16”-12UN (SAE-12), Tank Port: 1-5/16”-12UN (SAE-16), LS Port: 7/16”-18UNF (SAE-4)  
**B** – Supply Ports: G3/4”, Tank Port: G1”, LS Port G1/4”  
**Note:** LS port will not be included when fixed displacement inlet controller is selected.

---

**9 Active Pressure Ports**  
**1** – P1  
**2** – P2  
**3** – P3  
**4** – P1 & P2  
**5** – P1 & P3  
**6** – P2 & P3  
**7** – P1, P2 & P3  
**Note:** Selections with P1 port are preferred as primary pressure port but other options may be used depending on system layout.  
**Note:** All active ports will be capped with plastic shipping plugs.

**10 Inlet Pressure Controller**  
**FDP** – Used with fixed displacement pump  
**LSP** – Used with variable displacement load sense pump  
**FDM** – Used with fixed displacement pump when manual override option L1 or L2 is selected. Not required with S1, S2 or S3 manual options. See model code position 19.  
**LSM** – Used with variable displacement load sense pump when manual override option L1 or L2 is selected. Not required with S1, S2 or S3 manual options. See model code position 19.  
**000** – None - Used when interface module code is “E” or “0”

# Model Code

**Note:** Model code represents single valve bank. Multiple valve bank systems will have multiple model codes.

Z	T	S	1	6	*	*	*	*	C	*	*	*	*	*	*	*	*	*	*	*	*	*	*	*	*	*	*	*	*	*	*	*	0	0	*	*	*	1	0
1	2	3	4	5	6	7	8	9	10	11	12	13	14	15	16	17	18	19	20	21	22	23																	

## 11 Main Relief

- 000 – None
- 050 – 50 bar
- 350 – 350 bar

**Note:** The main relief is intended as a system relief. Relief setting available in increments of 10 bar.

**Note:** Position codes for 12 through 20 will repeat for each section.

## 12 Section

See drawing for work port labels

- A – Section
- B – Section
- C – Section
- D – Section
- E – Section
- F – Section

## 13 Thread Type

- J3 – 3/4"-16 UNF (SAE-8)
- J4 – 7/8"-14 UNF (SAE-10)
- J5 – 1-1/16"-12UN (SAE-12)

F3 – G3/8"

F4 – G1/2"

F5 – G3/4"

**Note:** "J" Threads meet SAE J1926/ISO 11926 standards; "F" Threads meet DIN 3852 Pt 2 standards.

## 14 Spool 1 Type

- HC – 130 lpm, biased to center
- HT – 130 lpm, biased to tank
- HP – 130 lpm, biased to pressure

## 15 Work Port Valves - Side 1

- 00 – None
- AS – Anti-Cav Valve with shock valve
- AC – Anti-Cav Valve
- SV – Shock Valve

## 16 Shock Valve Setting - Side 1

- 000 – None
- 050 – 50 bar
- 350 – 350 bar

**Note:** Available in increments of 10 bar, between 50 and 350 bar.

## 17 Spool 2 Type

- HC – 130 lpm, biased to center
- HT – 130 lpm, biased to tank
- HP – 130 lpm, biased to pressure

## 18 Work Port Valves - Side 2

- 00 – None
- AS – Anti-Cav Valve with shock valve
- AC – Anti-Cav Valve

## 19 Shock Valve Setting - Side 2

- 000 – None
- 050 – 50 bar
- 350 – 350 bar

**Note:** Available in increments of 10 bar, between 50 and 350 bar.

## 20 Manual Override

- 00 – None
- L1 – Lever-handle position from direction 1
- L2 – Lever-handle position from direction 2
- S1 – Single spool override - pos.1
- S2 – Single spool override - pos. 2
- S3 – Single spool override - pos.1 & pos. 2

**Note:** Manual override is not an alternative mode of manual actuation.

## 21 Special Features

- 00 – None

## 22 Software Version

XXX – Software version will be automatically populated

## 23 Design Code

- 10 – This section left blank intentionally

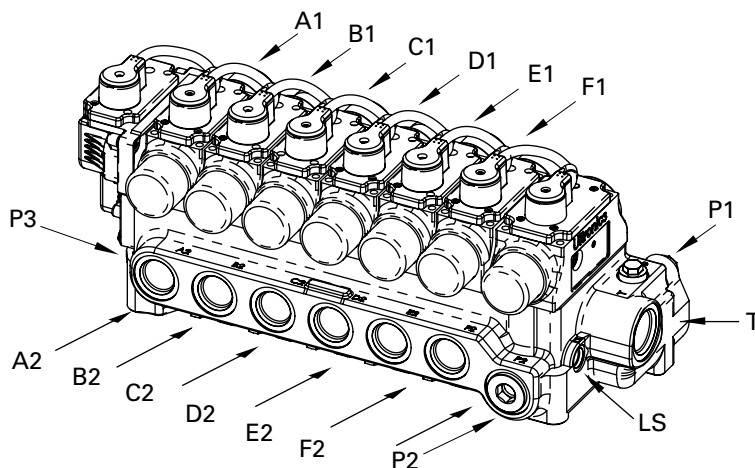

# Principles of Operation

## Valve Cross Section

1. Main stage monoblock casting
2. Mainstage spools
3. Pilot valve
4. Voice coil actuator
5. Centering spring
6. Pilot spools
7. Position sensor
8. Pressure sensor
9. On-board electronics

## Section Schematic

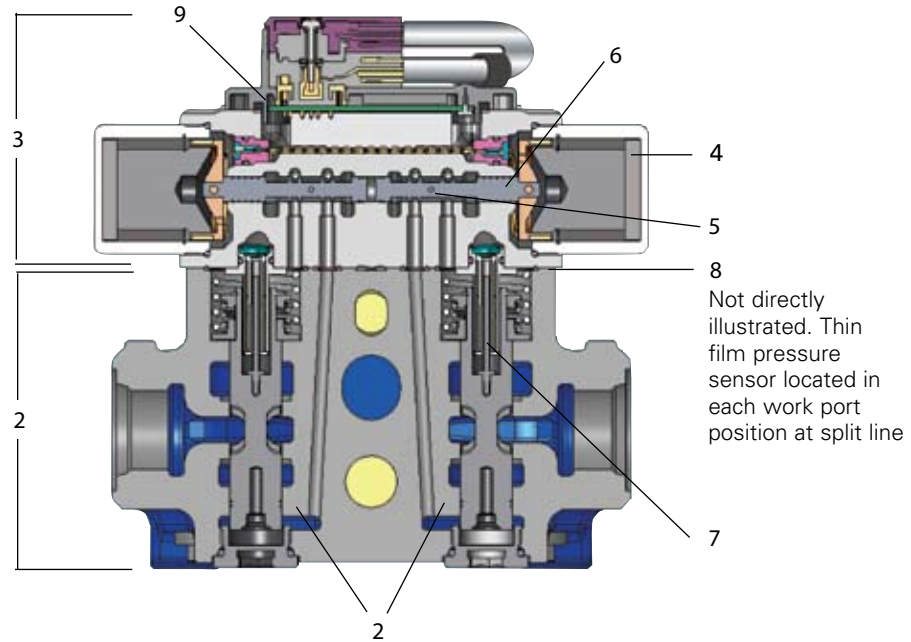

## Work Section

The work section is comprised of two independent spools (2) that act as a pair working to control double acting services, or alternatively as single spools controlling a single acting service (2 single axis services can be controlled from any work section).

Demands to each work section are transmitted over a CAN Bus and power is provided to each work section via a single daisy chain cable arrangement. Each work section has a single pilot valve comprised of on-board electronics (9), two independent 3 position 4 way pilot spools driven by low power bi-directional voice coil actuators (4), and embedded

sensors. The independent pilot spools control the mainstage spools.

Closed loop control of each work section is done locally by leveraging the on-board electronics and sensors. Each mainstage spool has its own LVDT position sensor (7) enabling closed loop position control of the mainstage spool. Further, a thin film pressure sensor (8) is located in each work port, pressure line and tank line. By knowing spool position and pressure drop across the orifice created by the mainstage spool, it is possible to calculate flow and thereby control flow per the equation to the right.

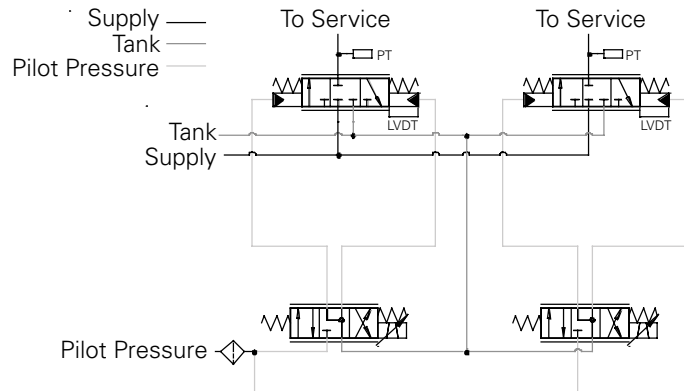

$$Q = C_d \cdot \rho_{(x, temp)} \cdot A \cdot \sqrt{\frac{2}{\rho_{(temp)}} \cdot \Delta P}$$

- Q** = Flow rate
- Cd** = Discharge Coefficient
- A** = Area
- ρ** = Density
- ΔP** = Pressure Drop

**Note:** the equation is above is representative only and does not represent exact control algorithm.



# Performance Data

**Inlet to Work Port**

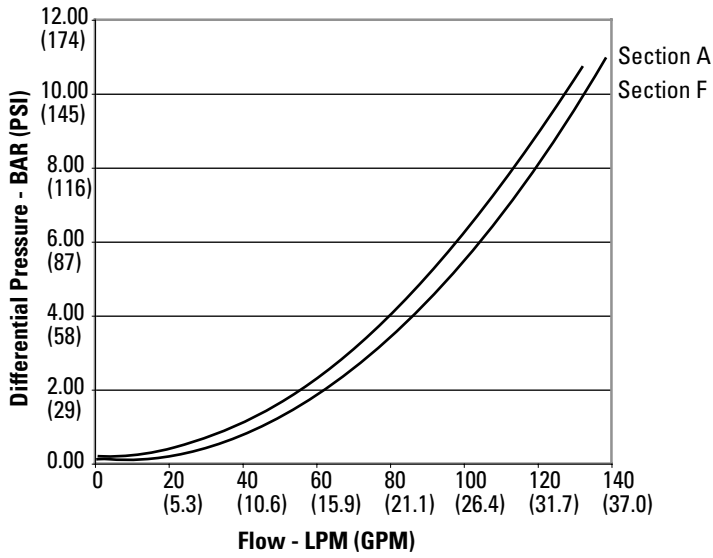

**Work Port to Tank**

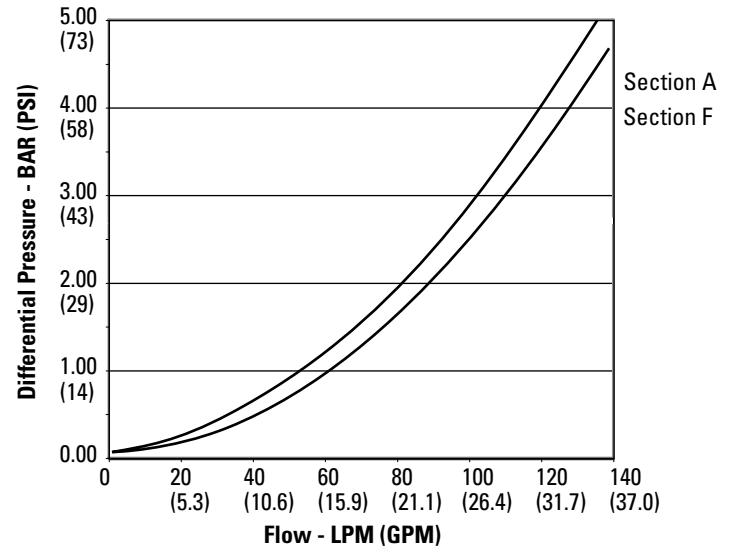

**Inlet Pressure Relief Override Curves**

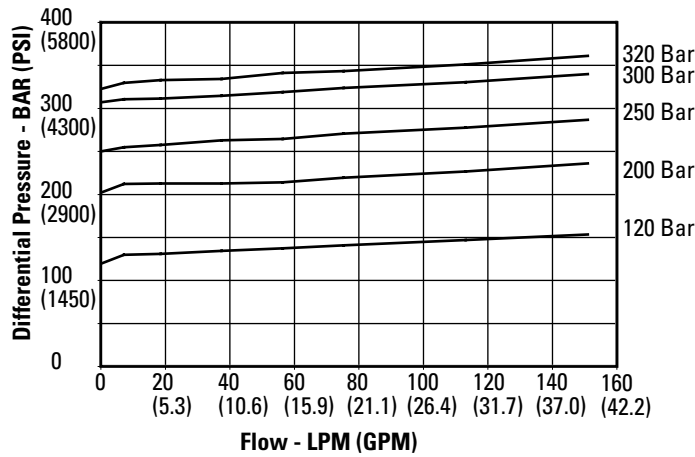

**Unloader Pressure Drop Curve**

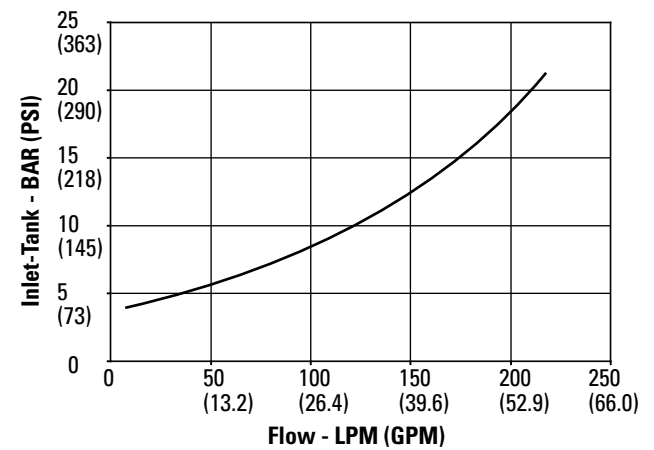

# Inlet Options

**Ultronics ZTS16 valve can be used with both fixed and variable displacement pumps.**

## Fixed Displacement Inlet

The fixed displacement inlet consists of a pilot valve that pilots a primary unloading spool. Based on the electronically demanded system pressure requirement, the primary spool either closes to restrict supply and thus

build system pressure or opens to allow flow to freely flow back to tank. A mechanical main system relief is included to provide for over pressure protection.

**Fixed displacement inlet schematic**

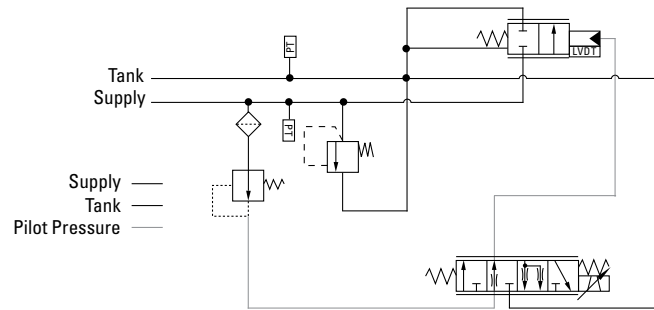

## Variable Displacement Inlet

Like the fixed displacement inlet, the variable displacement inlet consists of a primary spool controlled by a high performance pilot valve. The pilot valve provides pilot pressure to either side of the primary spool which meters supply flow, based on the electronic

load-sense demand, to create the hydraulic load sense signal necessary to actuate the pump compensator and ultimately the pump swash plate. A main relief is shown here, but not required as maximum system pressure is also controlled by pump compensator.

**Variable displacement inlet schematic**

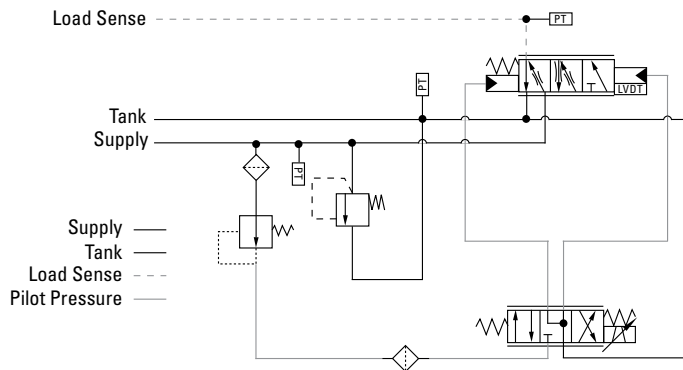

## Load Sense

Unlike traditional mobile valves, Ultronics does not have internal load-sense lines and check valves to communicate load pressures. Ultronics determines load sense pressures electronically via its embedded pressure sensors and

then communicates them via CAN Bus to the inlet pressure controller which controls system pressure. Since the load sense signal is electronic, load-sense margins for the system or specific valve sections are configurable via software.

# Flow Share Methods

## Flow Share Methods

Ultronics has three distinct, software configurable, flow share methods. All control methods are electronically compensated and perform the same until the pump

flow is fully consumed (fully saturated). After saturated, the valve will share flow according to one of the software selected methods identified below:

### “Ratio”

The Ratio method will reduce all non-priority flow demands by the same relative amount; i.e., the same percentage. This method permits the use of all flow services until the pump flow is fully consumed by priority services. As pump flow decreases, all non-priority

flow demands are reduced by the same percentage and would all reach a demand of zero at the same time. This method is similar to post-compensated, anti-saturation valve systems.

### “Cascading”

The Cascade method will reduce non-priority flow demands according to a priority rating. Each non-priority flow service is assigned a priority rating. The rating specifies the order in which the flow demands are reduced. This method allows higher priority services to run with their demanded flow unchanged, whilst lower

priority are reduced. As pump flow decreases, the higher priority flow demands remain unchanged but the lower priority flow demands are reduced. When the lowest priority flow demands hit zero, the next lowest priority demands are reduced.

### “Uniform”

The Uniform method will reduce all non-priority flow demands by the same actual amount. This method keeps services with higher flow demands operating in preference to services with low flow demands. As pump flow

decreases, all non-priority flow demands are reduced by the same numerical value, so all demands are reduced, but lower flow demands reach zero before higher flow demands.

Full Flow

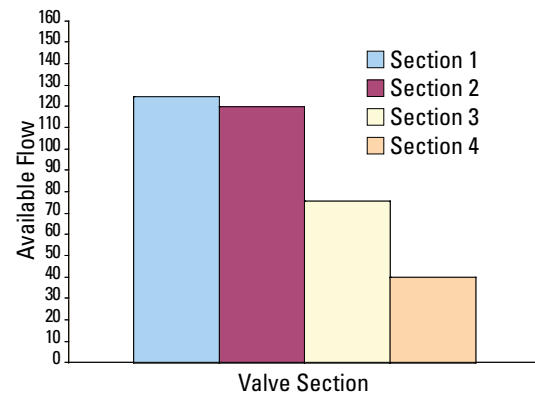

Reduced Flow-Ratio Method

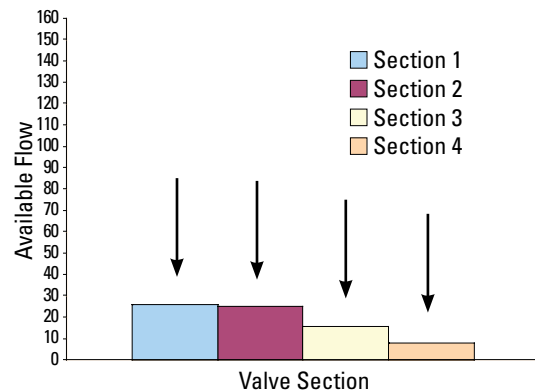

Reduced Flow-Ratio Cascading Method

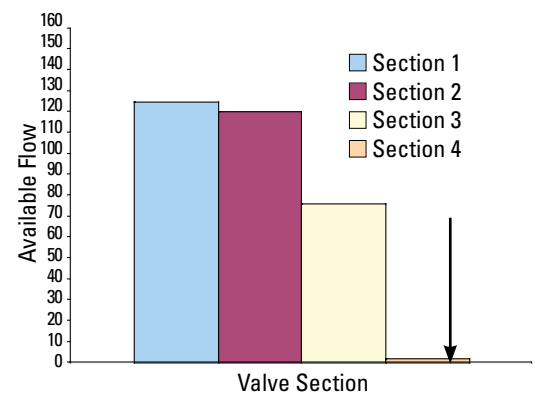

Reduced Flow-Ratio Uniform Method

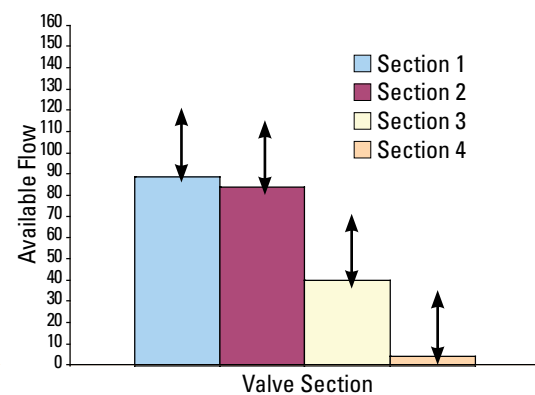

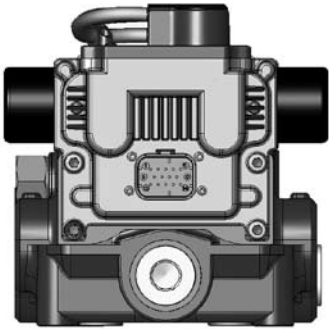

Power and control are provided to the Ultronic system through a 14 AMP connector on the Valve System Module (VSM). The VSM acts as a gateway between the vehicle CAN Bus and power and the Ultronic valve system. All valve control signals are transmitted over CAN Bus to the single source address assigned to the valve system.

If the total distance of the CAN Bus is less than 4 meters, it is possible to daisy chain the valve banks together using the standard 9-pin Ultronic connector.

If the total distance of the CAN Bus is greater than 4 meters, a Valve System Extender (VSE) must be used.

**Pin No. VSM** **14-way Connector Function** (Black Connector)

1	Battery +	Supply
2	Battery +	Supply
3	CAN_SHLD	CAN Shield (cable screen)
4	CAN_TRM_A	CAN terminate A
5	CAN_H	CAN High
6	Battery -	Supply Return
7	Battery -	Supply Return
8	CAN_TRM_B	CAN terminate B
9	CAN_L	CAN Low
10	ICOM_HIGH	Interconnect COM High
11	ICOM_LOW	Interconnect COM Low
12	ICOM_HIGH	Interconnect CAN High (pass through)
13	ICOM_LOW	Interconnect COM Low (pass through)
14	ICOM_TRM	Interconnect COM terminate

**Pin No. VSE** **14-way Connector Function** (Grey Connector)

1	Battery +	Supply
2	Battery +	Supply
3	Block ID A	
4	Block ID B	
5	Not Connected	
6	Battery -	Supply Return
7	Battery -	Supply Return
8	Not Connected	
9	Not Connected	
10	ICOM_HIGH	Interconnect COM High
11	ICOM_LOW	Interconnect COM Low
12	ICOM_HIGH	Interconnect CAN High (pass through)
13	ICOM_LOW	Interconnect COM Low (pass through)
14	ICOM_TRM	Interconnect COM terminate



**Note**

This product has been designed and tested to meet the requirements outlined in the EU directives 75/332/EEC and 89/336/EEC as amended by 2000/2/EC and 2004/108/EC respectively. Additionally, the product has been designed to meet the requirements of EU directive 72/245/EEC as amended by 2004/104/EC.

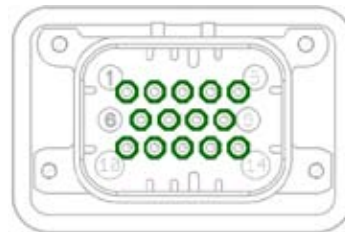

**14-Way Connector**

# System Layout

There are multiple interconnection options for Ultronic valve systems with more than one valve bank.

The following figures illustrate possible system configuration options for the Ultronic ZTS16. The configurations are representative only and do not represent all possible configurations. Configuration is dependent on application requirements and is constrained by the following rules:

- Maximum of 15 sections per system
- Each valve bank can have up to 6 sections
- One VSM and corresponding CV required per system
- If distance between a extension valve bank and the VSM or VSE is less than 4 meters, they can be connected using a daisy chain extension cable. See "Interbank Connection" options on page 16.
- If distance between valve banks is greater than 4 meters, they must be connected using VSE and external wiring harness.

**Layout Example: 2 Bank with VSE**

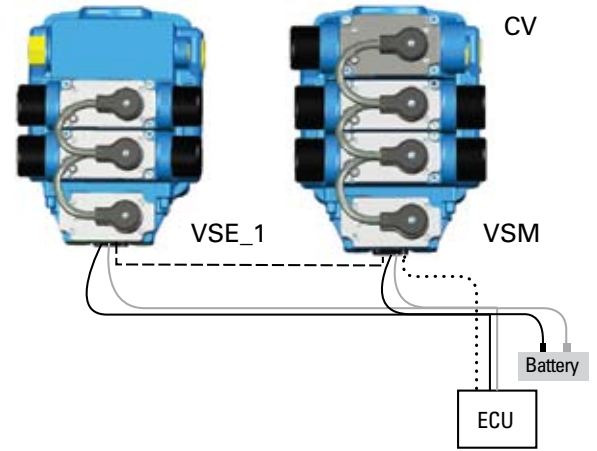

**Layout Example: 1 Bank**

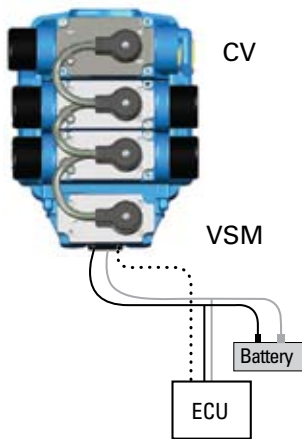

**Layout Example: 3 Bank with 2 VSEs**

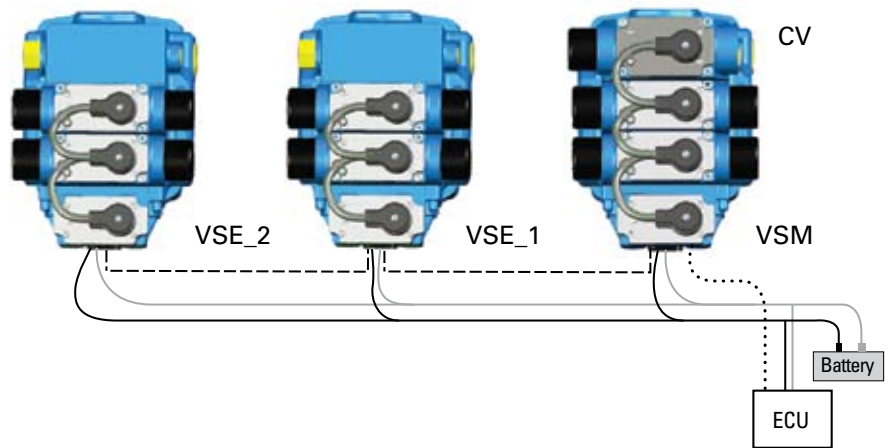

**Layout Example: 3 Bank with VSE and Daisy Chain**

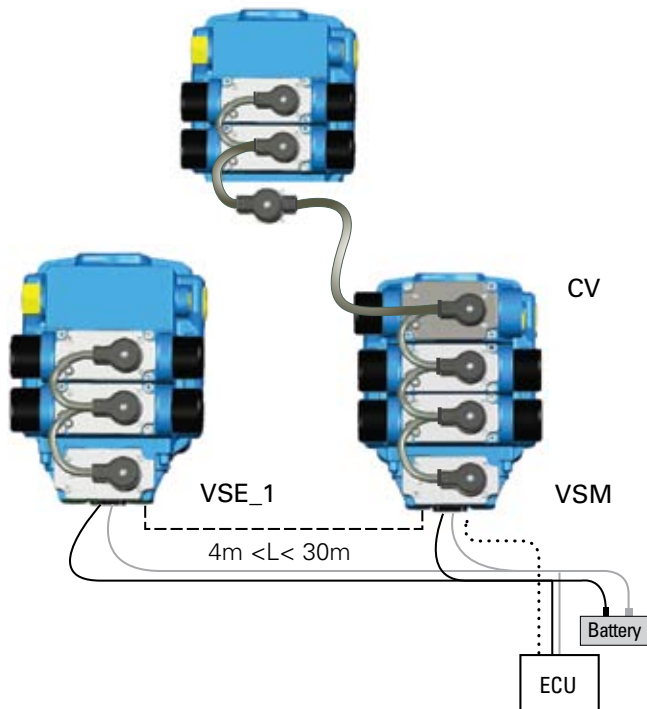

**Layout Example: 2 Bank with Daisy Chain**

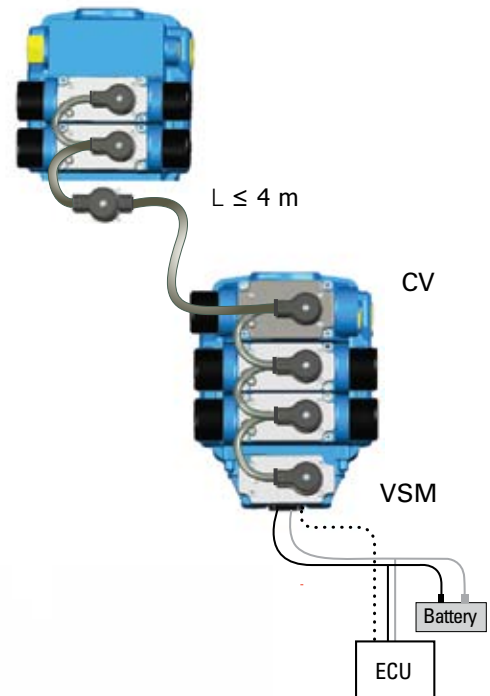

# Work Port Valves

The Ultrronics ZTS16 has three methods for controlling and limiting maximum port pressures.

- **Pressure Max** – above this pressure individual port flow will be regulated to limit pressure to this value. Also, the port will not accept a pressure demand above this limit. The Maximum Pressure Control value is set by software. This value should be set to what mechanical port reliefs/shock valves are set to in a traditional mobile valve.
- **Mechanical Shock Valve** – mechanical shock valves are optional and provide additional protection for load induced pressure spikes.
- **Software Relief** – when a load is induced above this value, the work port spool will service to tank. This value, at minimum, should be set +30 bar above mechanical relief or +40 bar above “Pressure Max”.

## Ultrronics ZTS16

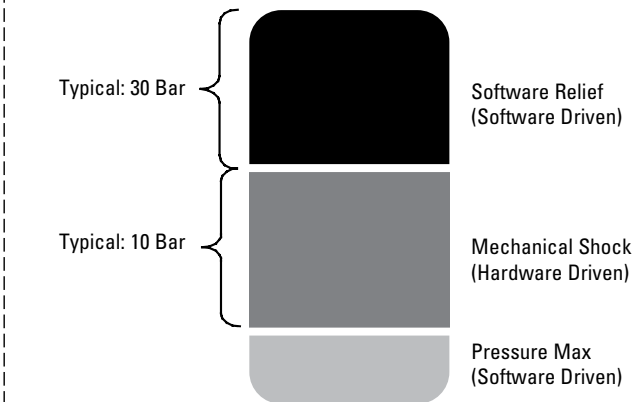

## Traditional Valves



## Mechanical Work Port Valve Options

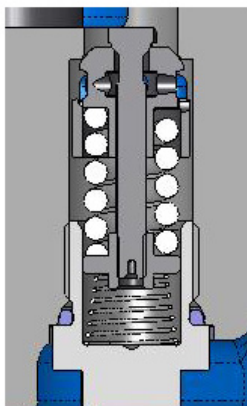

- Anti-cav + Shock Valve (AS)

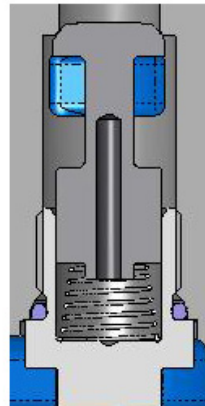
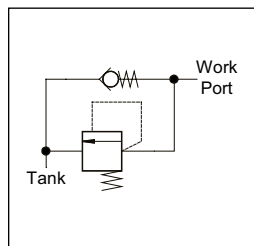

- Anti-cav Valve (AC):

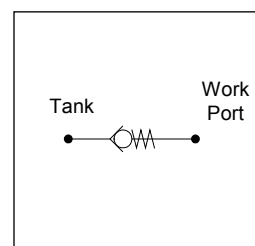

# Manual Override

## Lever- Handle Override

(L1 = handle on side 1; L2 = handle on side 2)

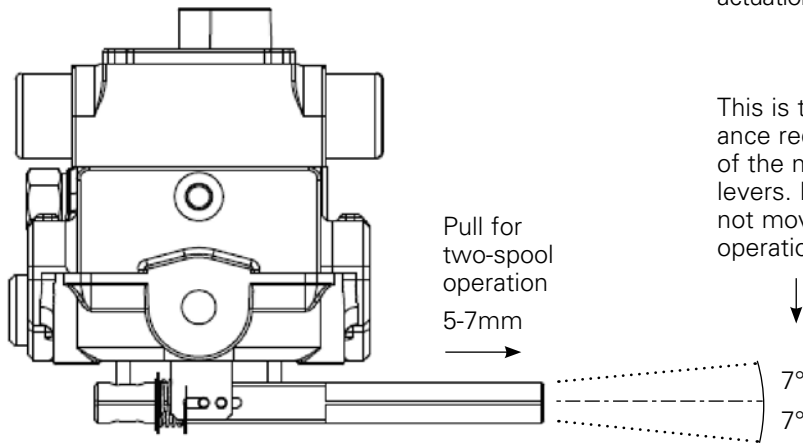

## Note:

Manual override is **not** an alternative mode of manual actuation.

This is the minimum clearance required for operation of the manual override levers. Note that levers do not move during normal operation of the valve.

Operation: Pull handle to engage and operate manual override. Moving the lever "up" will port fluid from P to P1, and from P2 to tank. Moving lever "down" will port fluid from P to P2, and from P1 to tank.

## Single-Spool Override

(S1 = side 1; S2 = side 2; S3 = both sides\*)

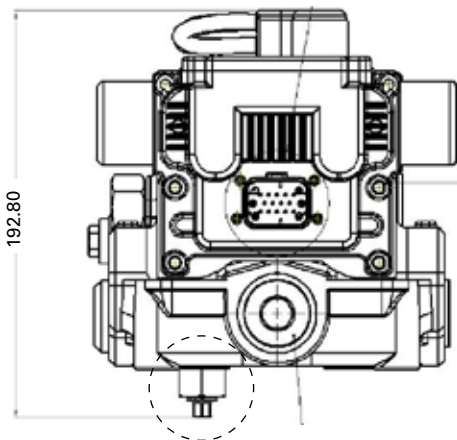

\*This is possible if each spool is acting as a single service for supply and return (i.e. spring return ram)

Operation: A captive hexagon nut on the spindle will drive towards the spool when the spindle is turned. This pushes the spool towards the tank only. If spool is biased to pressure, fluid will be relieved to service port then tank. If spool is biased to center, fluid will be relieved to tank. (If spool is biased to tank, fluid is already relieved to tank).

# Interbank Connection Cables

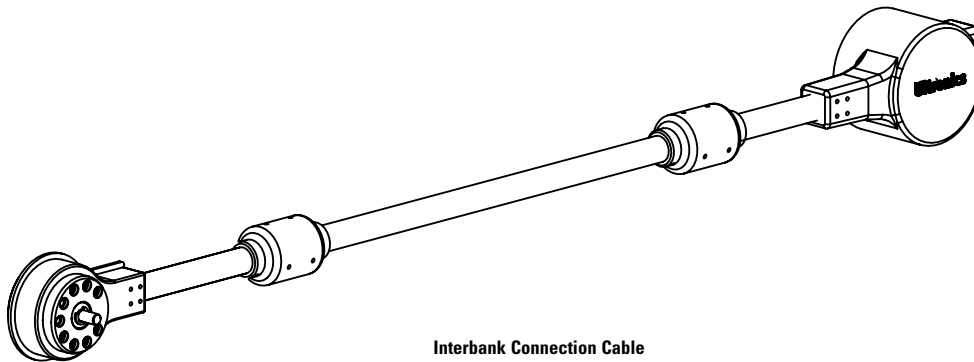

Interbank Connection Cable

Interbank Connection Cables	Part Numbers	Description
	2063-001-200	2.0 meter interconnection cable
	2063-001-400	4.0 meter interconnection cable

Note: If more than one cable is used in a single daisy chain with multiple valve banks, then the combined lengths must be  $\leq 4\text{m}$ .

CAN Bus Terminator Assembly	Part Numbers	Description
	2059-030-00L	120 ohm CAN Bus terminator

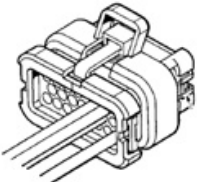
14-Way Connector (AMP Plug)	Part Numbers	Description
	9615-091-BKM	Black 14-way plug assembly kit (VSM)
	9615-092-GKY	Grey 14-way plug assembly kit (VSE)



# Installation Drawing

**Note:** All dimensions are in millimeters.

AMPSEAL 14-WAY CONNECTOR

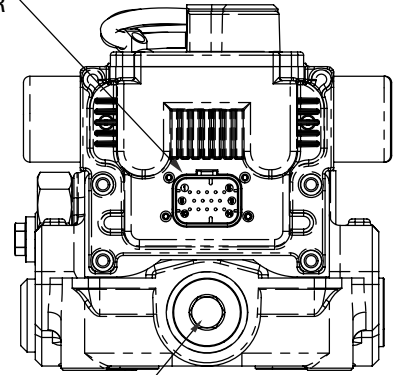

P3 PORT  
Alternative Supply Port  
(Supplied Plugged)

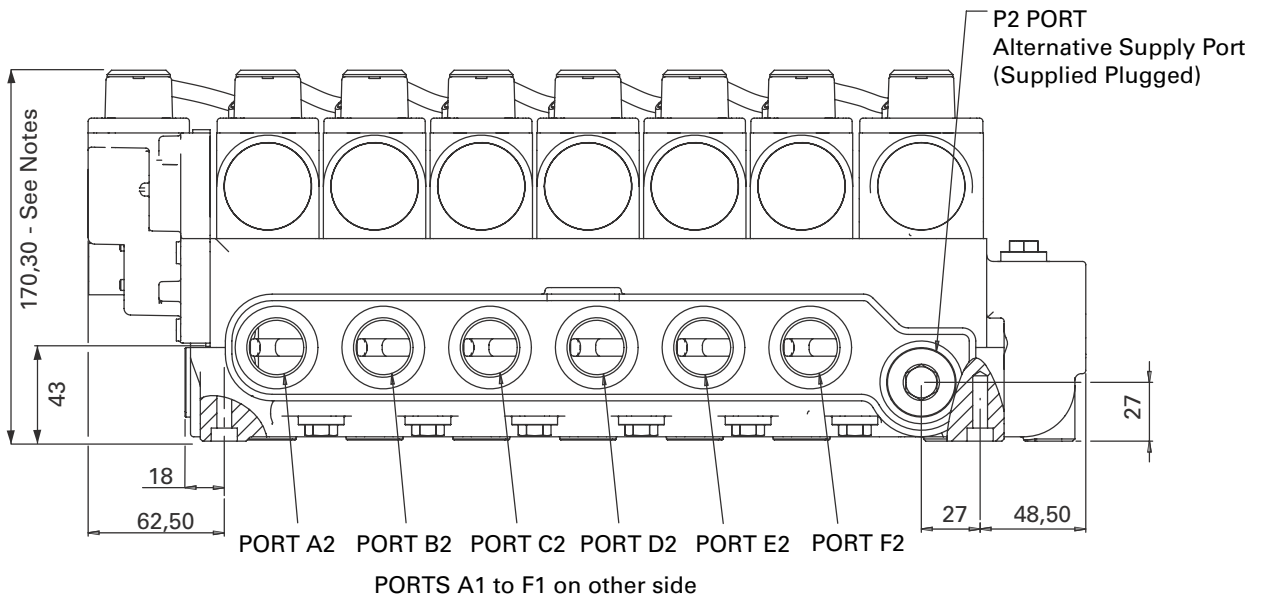

458 REF  
Overall Length - See Table

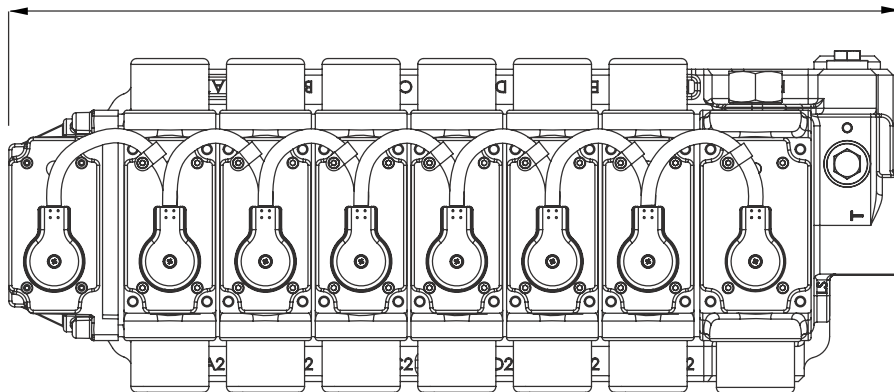

# Installation Drawing

**Note:** All dimensions are in millimeters.

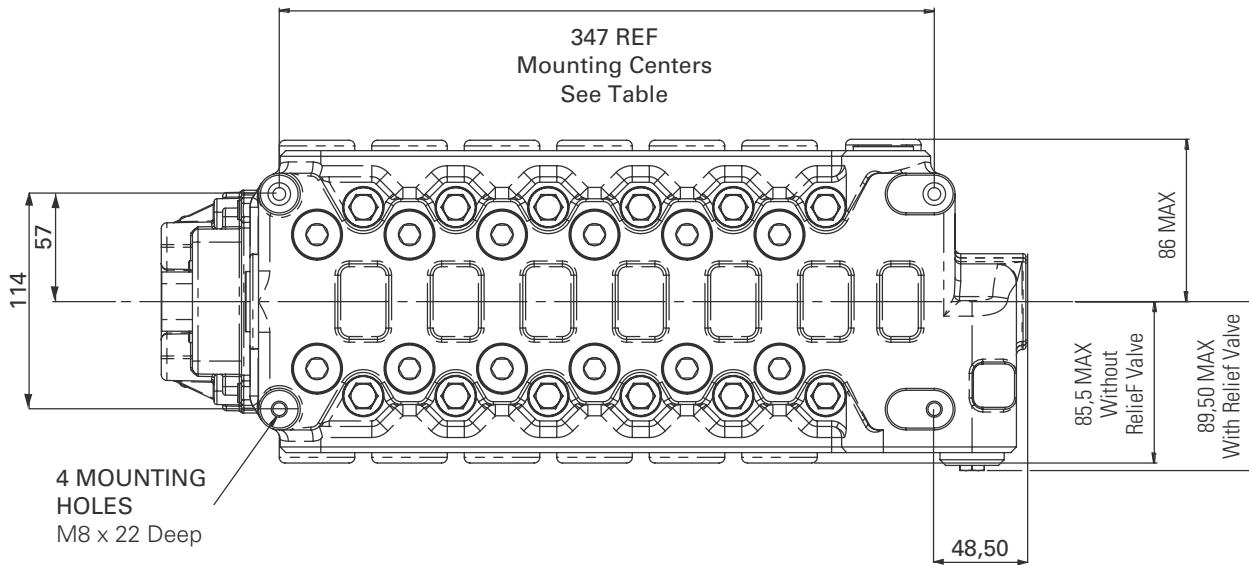
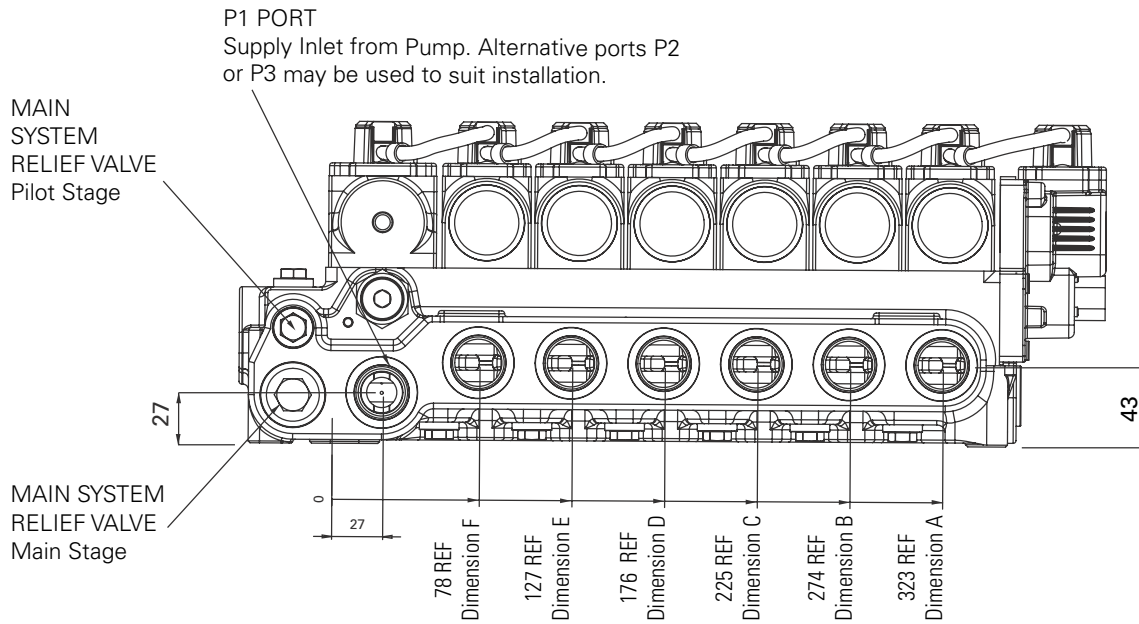
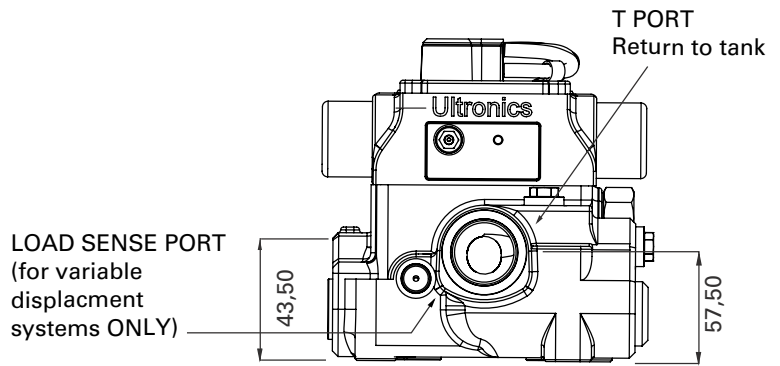

Number of Valve Sections	Mounting Centers	Overall Length	Dim. a	Dim. b	Dim. c	Dim. d	Dim. e	Dim. f
1	102	213	78	x	x	x	x	x
2	151	262	127	78	x	x	x	x
3	200	311	176	127	78	x	x	x
4	249	360	225	176	127	78	x	x
5	298	409	274	225	176	127	78	x
6	347	458	323	274	225	176	127	78

**Eaton**  
Hydraulics Group USA  
14615 Lone Oak Road  
Eden Prairie, MN 55344  
USA  
Tel: 952-937-9800  
Fax: 952-294-7722  
[www.eaton.com/hydraulics](http://www.eaton.com/hydraulics)

**Eaton**  
Hydraulics Group Europe  
Route de la Longeraie 7  
1110 Morges  
Switzerland  
Tel: +41 (0) 21 811 4600  
Fax: +41 (0) 21 811 4601

**Eaton**  
Hydraulics Group Asia Pacific  
Eaton Building  
4<sup>th</sup> Floor, No. 3 Lane 280 Linhong Rd.  
Changning District  
Shanghai 200335  
China  
Tel: (+86 21) 5200 0099  
Fax: (+86 21) 5200 0400